

# Gatesafe Technical Specifications

The Gatesafe finger pinch protector guard is installed on the push-side of the opening. It is made to protect industrial doors and gates.

## Material

Made in the USA. Constructed of aluminum brackets and Santoprene. Retrofitted using screws.

## Overall Width

3" Flat, 13 1/2" expanded

## Length

Stock size is 79", can be cut to size

## Color

Black

## Durability

Durability: U.V. and high impact resistance. For interior or exterior gates and industrial openings. Easily cleaned.

## Performance

Designed to prevent hand, finger, arm crushing in hinge area of gates and industrial openings. Can be installed push or pull side and allows even an opening to open to 180 degrees. It also offers draft exclusion and is a smoke inhibitor.

## Availability and Cost

Fingersafe Gatesafe are stocked in 80" with a one week turn around. A two year warranty is offered on fair wear and tear, supply only. Samples may be supplied on request to a potential client for evaluation purposes.



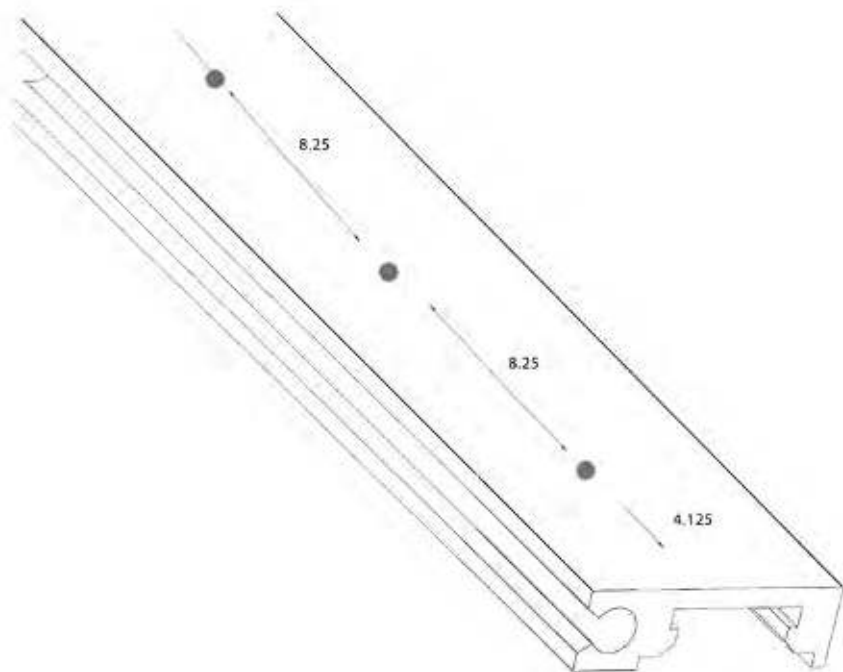
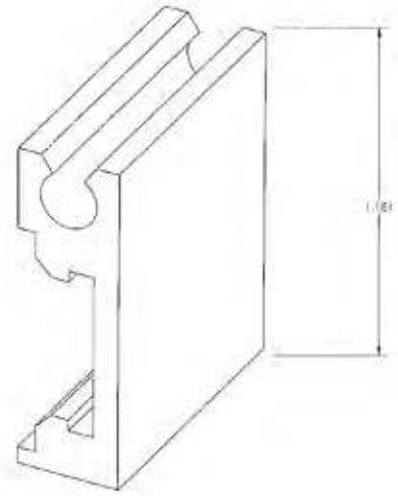
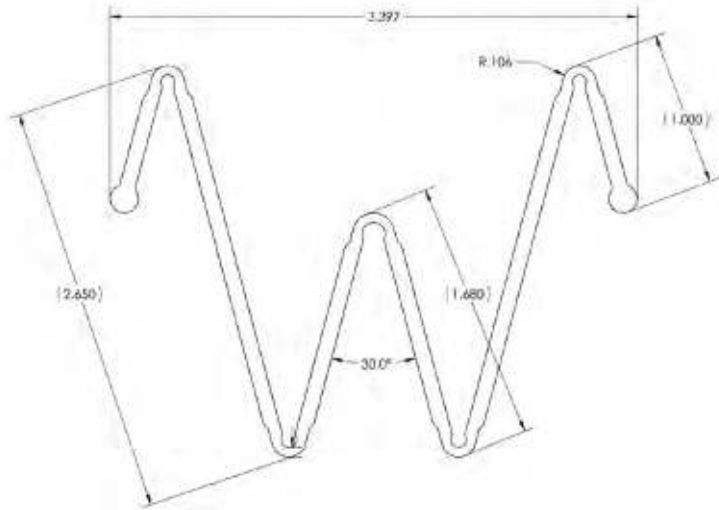

## **GateSafe/Industrial FITTING INSTRUCTIONS**

Fingersafe is easy to fit and very reliable when installed correctly. It is essential that these instructions are followed carefully.

### **Tools required for fitting Fingersafe Industrial**

1. Cordless drill
2. Phillips drill bit
3. 3/32 titanium drill bit for pre-drilling
4. Self drilling screws for wood, metal & aluminium doors (provided)

### **INSTALLATION CHECKLIST**

1. Measure from the bottom of the opening to the top of the opening (with door/gate firmly closed) cut the GateSafe to length if necessary to allow clearance top to bottom.
2. Remove cosmetic gray strip from both sides of your GateSafe.
3. Install using screws that are provided, pre-drill if needed.
4. Snap cosmetic gray strip back into place to cover screws.
5. Your Gate is now "Fingersafe"!

**Many applications require product modifications, we do not accept returns on any cut or altered product. GateSafe/Fingersafe Industrial has a 5 year warranty for normal wear and tear.**